



M&S Armaturen GmbH

PARTNER INSTEAD OF SUPPLIER.

# Operation Manual

*-Translation of the original-*

**Butterfly valve SV04 DIN / INCH**

**M&S Article No. 5XXX4 - 5XX40**



M & S Armaturen GmbH  
Industriestraße 24-26 - 26446 Friedeburg - Germany  
fon +49(0)4465 807 0 - fax +49(0)4465 807 40  
[www.ms-armaturen.de](http://www.ms-armaturen.de)

Rev.4 / 01.04.2018  
BA52240GB.docx

## 1 Table of Contents

1	Table of Contents .....	2
2	Safety advice .....	3
2.1	Marking of safety instructions in operating instructions .....	3
2.2	Intended use .....	3
2.3	Personnel .....	3
2.4	General instructions .....	3
3	Use and operating principle .....	4
4	Transport and storage .....	4
4.1	Transport .....	4
5	Installation / disassembly / assembly .....	5
5.1	Installation .....	5
5.1.1	Installation butterfly valve type SV04 with thread or clamping connection on both sides	5
5.1.2	Installation butterfly valve type SV04 with weld-in connection .....	6
5.1.3	Installation butterfly valve type SV04 BF (between flanges) .....	7
5.2	Disassembly .....	8
5.2.1	Disassembly butterfly valve SV04 with handle HB04 .....	8
5.2.2	Disassembly butterfly valve type SV04 with pneumatic actuator PAMS .....	9
5.2.3	Disassembly butterfly valve SV04 BF with HB04 or PAMS .....	10
5.3	Assembly of the butterfly valve gasket .....	11
5.4	Assembly butterfly valve type SV04 with HB04 or PAMS .....	11
6	Repairs/Maintenance .....	12
7	Cleaning .....	12
8	Technical Data .....	13
8.1	Materials .....	13
8.2	Permissible operating pressures butterfly valve type SV04 .....	13
8.3	Flow coefficients ( $K_v$ -values) butterfly valve type SV04 .....	14
8.4	Torques and permissible operating pressures PAMS .....	14
8.5	Requirements control air for PAMS .....	14
9	Optional trigger and query systems .....	15
9.1	End position feedback .....	15
9.2	Control and feedback head TOP LED .....	15
9.3	Control head AS-i .....	16
9.4	Electro-pneumatic position controller (EPPC) .....	17
9.5	Electro-pneumatic process controller (EPPC/PR) .....	17



## 2 Safety advice

### 2.1 Marking of safety instructions in operating instructions



#### **Danger warnings**

Danger warnings are denoted by the danger symbol which appears on the left and are framed.



#### **Information**

Descriptions to which particular attention must be paid are denoted by this symbol which appears on the left and are also framed.

### 2.2 Intended use

The M&S butterfly valves SV04 are only intended for use as described. Any use beyond that is considered to be improper use. M&S is not liable for any resulting damage, the risk is solely with the operator. Requirement for perfect safe operation of the valve are proper transport and storage as well as professional set-up and assembly. Proper use also includes adherence to the requirements for operation, maintenance and repair. Unauthorised changes and modifications that impair the safety of the valve are not permitted. Only use original spare parts and accessories approved by the manufacturer.

### 2.3 Personnel

Operating and maintenance personnel must be qualified for the respective tasks. They must have had special instructions about any occurring hazards and must know and observe the safety advices mentioned in the operating instructions.

### 2.4 General instructions

The used is obliged to operate the valve in perfect condition only. Apart from the operating instructions, the following apply

- pertinent regulations on the prevention of accidents
- generally accepted safety-related rules
- internal work and safety regulations



### 3 Use and operating principle

M&S butterfly valves are used to open and close (partially or completely) pipeline sections. They are mainly used for liquids in pipelines, power units and tanks and containers.

The butterfly valves are pressure-containing equipment in the sense of EC Directive 2014/68/EU regarding pressure equipment. They are classified according to Annex II in Article 4, Paragraph 3 and must therefore not receive a CE-marking.

### 4 Transport and storage



When you receive the butterfly valve, check the information on order and delivery papers to make sure they correspond.

Check that the delivery is complete, and check its condition.

If there are visible signs of transit damage and/or packing units are missing, notify the forwarding agent immediately in the consignment note. You (the recipient) should take recourse against the forwarding agent immediately in writing, and M&S Armaturen GmbH must be informed of this action.

Complaints regarding transit damage that is not immediately evident must be made to the forwarding agent within 6 days.

The recipient must bear the costs for claims made after this period.

#### 4.1 Transport



The packing units/valves must only be transported using suitable lifting equipment and slinging gear.

Pay attention to the graphic symbols on the packaging.

Transport the butterfly valve carefully to prevent damage from sudden impacts; exercise due care when loading/unloading.



## 5 Installation / disassembly / assembly

### 5.1 Installation



Install the butterfly valve without tension into the pipeline system.

The butterfly valve can be installed in any installation position.

When installing the installation type SV04 with weld-in connection, pay attention to correct alignment of the handle or the pneumatic actuator, respectively.

After installation, the butterfly valve has to be actuated manually or pneumatically.

In the case of valves or systems used in potentially explosive atmospheres (see valid ATEX directives EC), potential equalization must be ensured.

#### 5.1.1 Installation butterfly valve type SV04 with thread or clamping connection on both sides

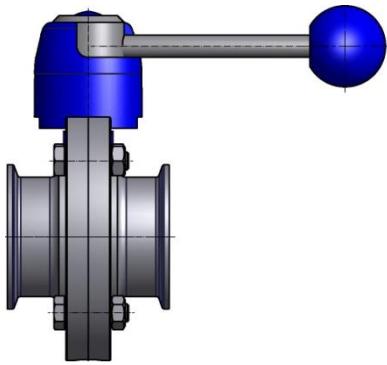

Figure 1  
Butterfly valve SV04 CC  
DIN/inch  
Art.-No.: 54440/54404

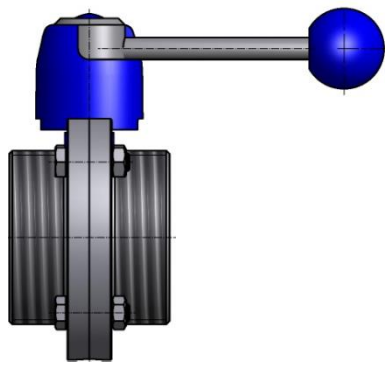

Figure 2  
Butterfly valve SV04 MM  
DIN/inch  
Art.-No.: 55540/55504

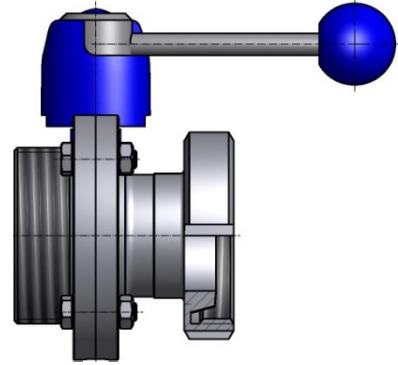

Figure 3  
Butterfly valve SV04 ML  
DIN/inch  
Art.-No.: 55604/55640

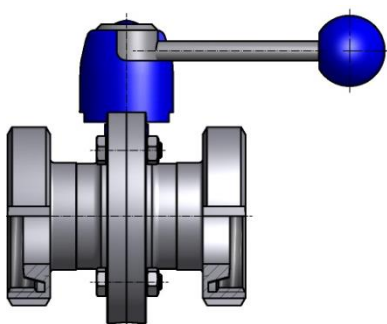

Figure 4  
Butterfly valve DA  
DIN  
Art.-No.: 56640

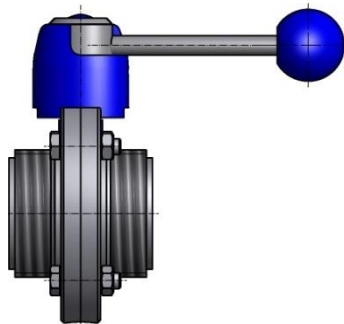

Figure 5  
Butterfly valve SV04 MM  
IDF/DS/RJT/SMS  
Art.-No.: 55544/55554/55564/55574

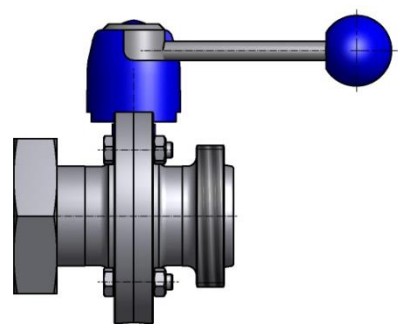

Figure 6  
Butterfly valve SV04 LM  
IDF/DS/RJT/SMS  
Art.-No.: 56544/56554/56564/56474

The butterfly valve type SV04 with thread or clamp connection on both ends (see figures 1-6) is delivered ready for installation. During installation into the pipeline system, make sure to pay attention to tension-free seat (pipe connections plane parallel and centred to each other).



Butterfly valve SV04 DIN / INCH

## 5.1.2 Installation butterfly valve type SV04 with weld-in connection

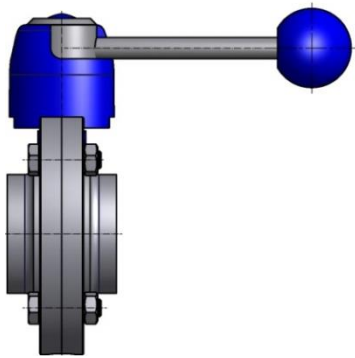

**Figure 7**  
Butterfly valve SV04 WW  
DIN/inch/ISO  
Art.-No.: 52240/52204/52248

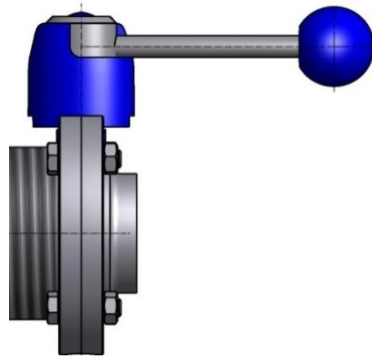

**Figure 8**  
Butterfly valve SV04 MW  
DIN/inch  
Art.-No.: 55240/55243/55204

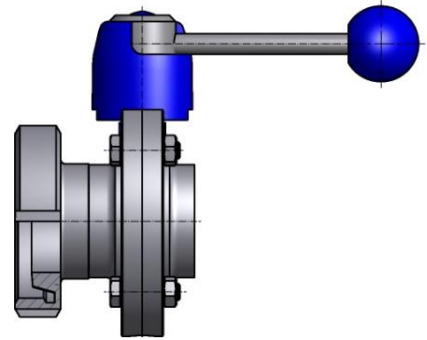

**Figure 9**  
Butterfly valve SV04 LW  
DIN/inch  
Art.-No.: 56240/56204

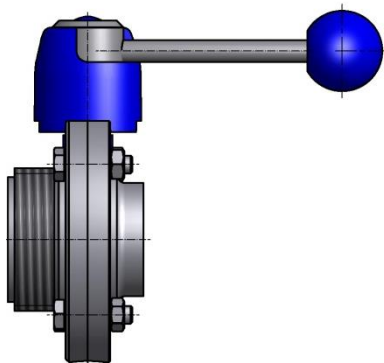

**Figure 10**  
Butterfly valve SV04 MW  
IDF  
Art.-No.: 55244

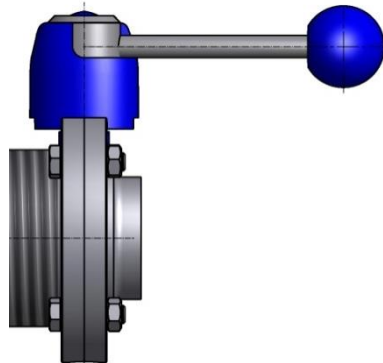

**Figure 11**  
Butterfly valve SV04 MW  
DS/SMS  
Art.-No.: 55254/55274

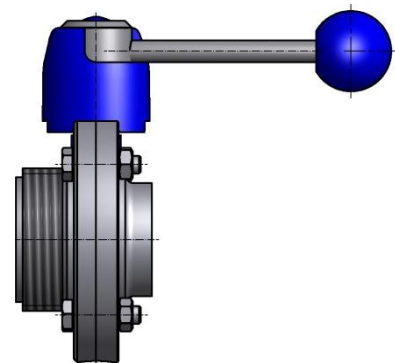
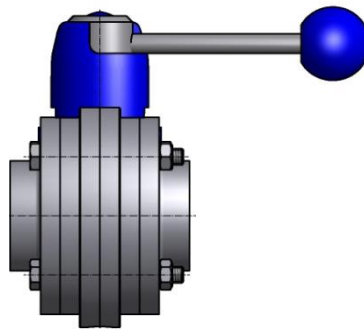

**Figure 12**  
Butterfly valve SV04 MW  
RJT  
Art.-No.: 55264

The butterfly valve type SV04 with weld-in connection on one or both ends (see figures 7-12) must be completely dismantled before welding it in (see chapter Disassembly). All components must be removed from the valve. The welding must then be done in partially assembled state without actuator, gasket, disc, friction bearing and plug. When welding, pay attention not to transmit any outer deformation tension to the butterfly valve. The subsequent assembly may only be done after the part has cooled down and been cleaned.



### 5.1.3 Installation butterfly valve type SV04 BF (between flanges)



**Figure 13**  
**Butterfly valve SV04 BF**  
**DIN/inch**  
**Art.-No.: 56040/56004**

Before installation of the butterfly valve type SV04 BF (see figure 13), the handle or the actuator with the bracket have to be removed. Furthermore, separate the counter flanges from the valve body (see chapter Disassembly). The counter flanges are welded to the given pipelines. The drilling pattern of both flanges must be aligned. The subsequent assembly may only be done after the part has cooled down and been cleaned.

## 5.2 Disassembly



Butterfly valves may only be disassembled by specialist personnel who have received the necessary technical training, and are equipped with the experience and knowledge to carry out the tasks involved.

### 5.2.1 Disassembly butterfly valve SV04 with handle HB04

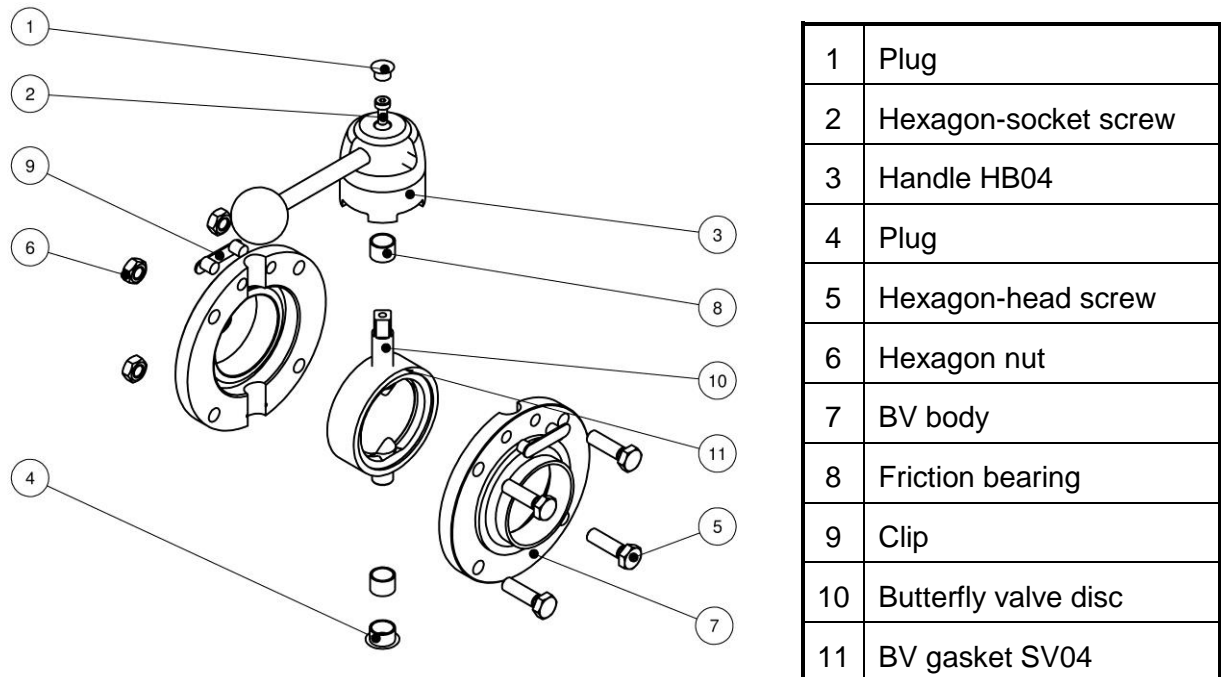

Figure 14 Disassembly butterfly valve SV04 with handle HB04

- Remove plugs (1,4)
- Pull lever off the handle HB04 (3) and then undo accessible hexagon-socket screw (2) using an Allen key size 4
- Remove handle HB04 (3) completely
- Undo the hexagon screws (5) and hexagon nuts (6)
- Pull the BV body (7) apart.
- Remove butterfly valve disc (10) together with the BV gasket (11) and friction bearing (8)
- Remove BV gasket (11) and friction bearing (8) from the butterfly valve disc (8)





## 5.2.2 Disassembly butterfly valve type SV04 with pneumatic actuator PAMS

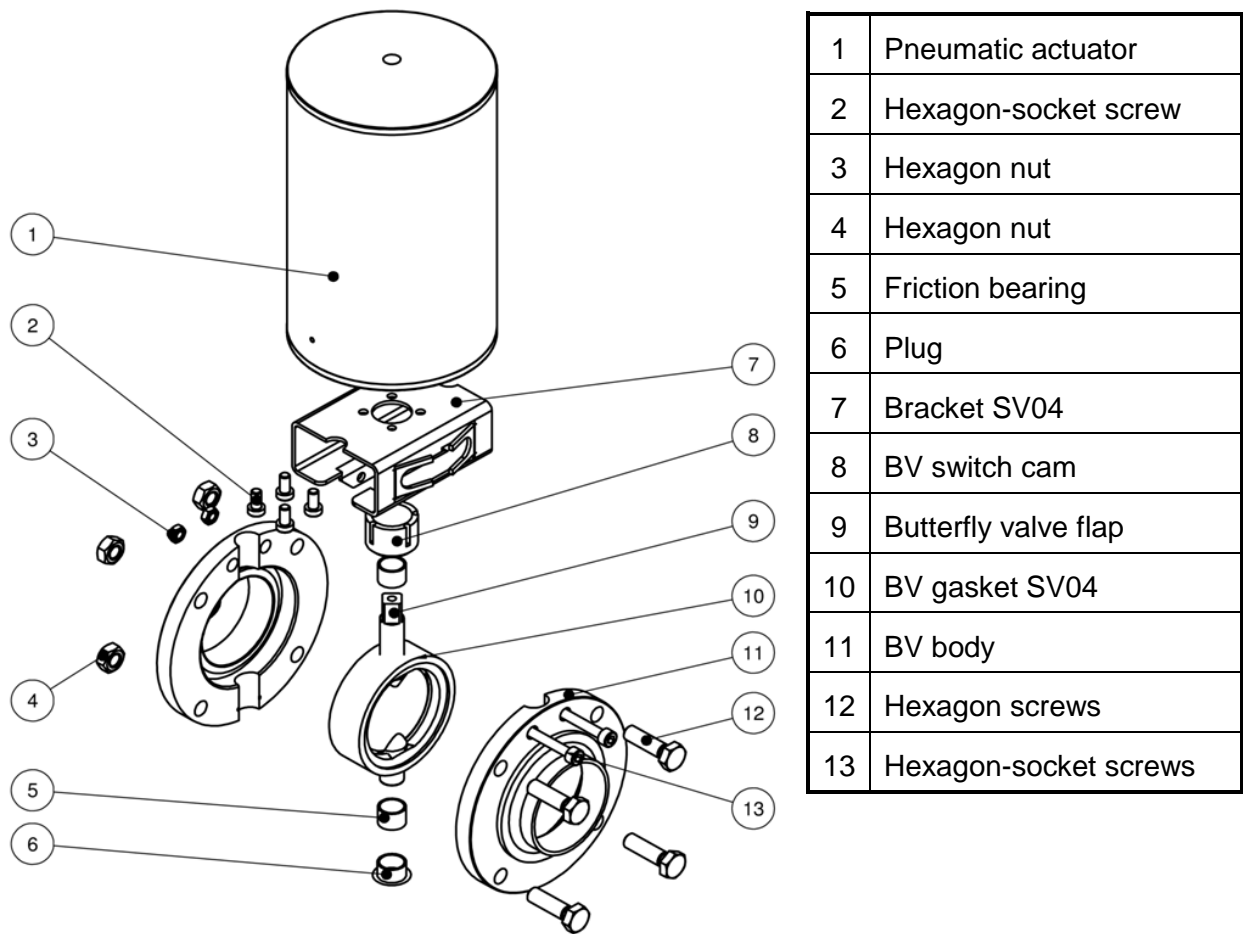

Figure 15 Disassembly butterfly valve type SV04 with pneumatic actuator PAMS

- Undo and remove hexagon-socket screws (13) and hexagon nuts (3)
- Remove the pneumatic actuator (1) completely with bracket (7) from the valve
- Remove BV switch cam (8) and plugs (6)
- Undo the hexagon screws (12) and hexagon nuts (4)
- Pull the BV body (11) apart.
- Remove butterfly valve disc (9) together with the BV gasket (10) and friction bearing (5)
- Remove BV gasket (10) and friction bearing (5) from the valve disc (9)

### 5.2.3 Disassembly butterfly valve SV04 BF with HB04 or PAMS

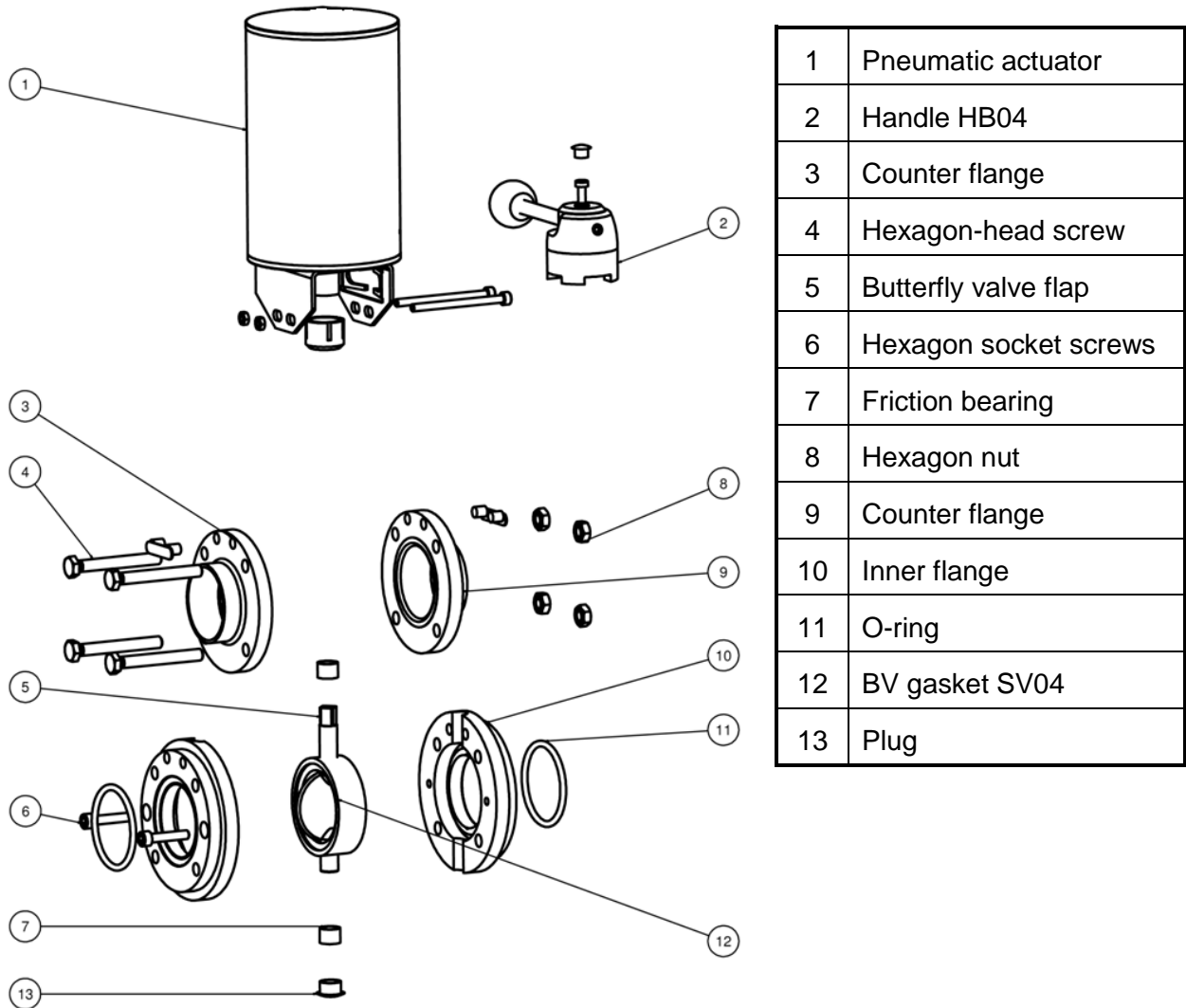

Figure 16 Disassembly butterfly valve SV04 BF with HB04 or PAMS

- Disassemble pneumatic actuator (1) or handle HB04 (2), respectively (see chapter 5.2.2 or 5.2.3)
- Undo and remove the hexagon screws (4) and hexagon nuts (8)
- Separate the counter flanges (3,9) from the valve body
- Undo hexagon-socket screws (6) and remove plugs (13)
- Pull inner flanges (10) apart
- Remove butterfly valve disc (5) together with the BV gasket (12) and friction bearing (7)
- Remove BV gasket (12) and friction bearing (7) from the butterfly valve disc (5)
- Replace any damaged O-rings (6)



### 5.3 Assembly of the butterfly valve gasket



During assembly make sure not to damage the gasket.

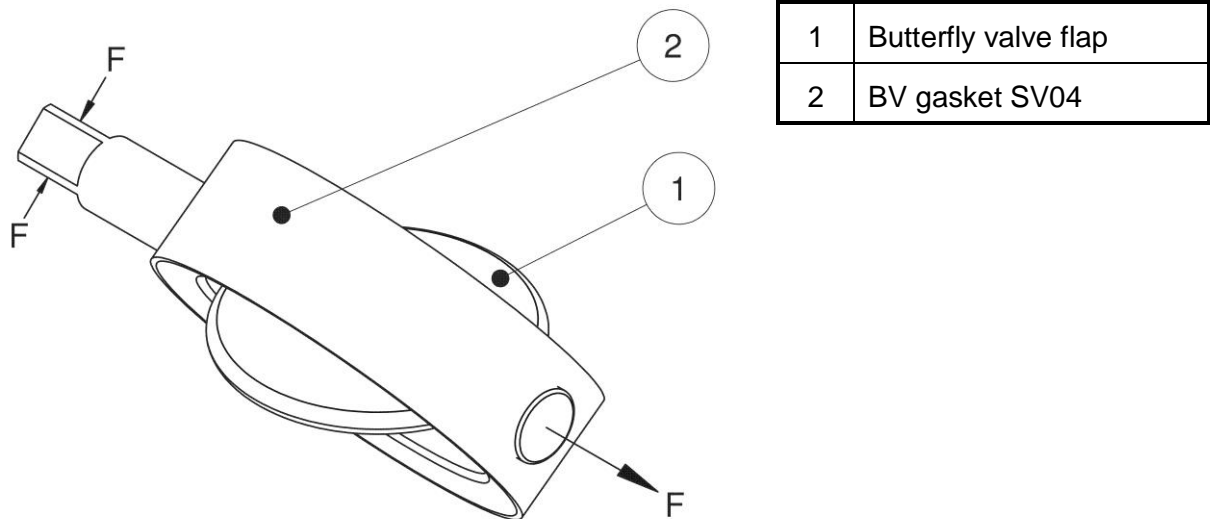

Figure 17 Assembly of the butterfly valve gasket

- Clean the butterfly valve disc (1) and slightly grease the drilled holes of the BV gasket (2) with a lubricant suitable for the process and the elastomer.
- Carefully push the butterfly valve disc (1) at the square side through an axle hole of the gasket, using a suitable tool if necessary.
- Clamp the butterfly valve disc (1) with the BV gasket (2) mounted on one side at its square e.g. in a vice.
- Turn the BV gasket (2) until it is at a 90° angle to the butterfly valve disc (1).
- Pull the BV gasket (2) manually with its free hole over the exposed end of the butterfly valve disc (1)
- Unclamp the butterfly valve disc (1) with the BV gasket (2) mounted.

### 5.4 Assembly butterfly valve type SV04 with HB04 or PAMS

Assemble the butterfly valve in reverse order to disassembly (see 6.2)



Butterfly valve SV04 DIN / INCH

## 6 Repairs/Maintenance



In order to ensure highest operational safety of the butterfly valves, replace all wear parts on a regular basis.

The maintenance intervals differ from case to case, the operator should define them by himself basing on sporadic checks.



M&S Armaturen GmbH cannot accept liability for claims made as a result of nonobservance of these Operating Instructions or constructional changes to the butterfly valve.

Any other use or use outside the defined scope is considered to be improper use. M&S Armaturen GmbH will not accept liability for losses incurred as a result of improper use.

## 7 Cleaning



Observe the safety data sheets by the cleaning agent manufacturers! Only use cleaning agents that do not attack stainless steel, elastomer nor plastic.

- For best cleaning results, keep the valve open during cleaning to completely rinse the gasket and the valve head.



## 8 Technical Data

### 8.1 Materials

Material: 1.4301/1.4307 - AISI 304/304L (in contact with product)

1.4404 - AISI 316L (in contact with product)

Gaskets: VMQ, EPDM, FKM, HNBR

### 8.2 Permissible operating pressures butterfly valve type SV04

Table 1: Permissible operating pressures butterfly valve type SV04

DN		max. permissible operating pressure [MPa]	Max. permitted operating pressure [bar]	max. permissible operating temperature [°C]
15-25	1"	1.0	10	Elastomer dependent
32				
40	1.5"			
50	2"			
65	2.5"			
80	3"			
100	4"			
125				
150				



### 8.3 Flow coefficients ( $K_V$ -values) butterfly valve type SV04

Table 2: Flow coefficients ( $K_V$ -values) butterfly valve type SV04

DN	15	20	25	32	40	50	65	80	100	125	150	
$K_V$ [m <sup>3</sup> /h]	12	20	28	50	78	130	200	290	450	610	800	

DN			33.7	42.4	48.3	60.3	76.1	88.9	114.3
$K_V$ [m <sup>3</sup> /h]			28	50	78	130	200	290	450

DN			1"		1.5"	2"	2.5"	3"	4"
$K_V$ [m <sup>3</sup> /h]			20		70	122	175	230	440

### 8.4 Torques and permissible operating pressures PAMS

Table 3: Torques, permissible operating pressures and air consumption

Variant	Maximum closing moment [Nm]	Operating pressure [MPa]	Operating pressure [bar]	Air consumption [l/stroke]
NC/NO size 0	35	0.48-0.80	4.8-8.0	0.8-1.2
NC/NO size 1	65	0.48-0.80	4.8-8.0	1.2-2.0
NC/NO size 2	100	0.48-0.80	4.8-8.0	3.0-5.0
DA size 0	50 (6bar)	0.30-0.80	3.0-8.0	0.5-1.2
DA size 1	80 (6bar)	0.30-0.80	3.0-8.0	0.8-2.0
DA size 2	130 (6bar)	0.30-0.80	3.0-8.0	1.9-5.0

### 8.5 Requirements control air for PAMS

Table 4: Requirements control air for PAMS

Requirement	Quality class	Standard
Solids content	6	acc. to ISO 8573-1
Water content	4	acc. to ISO 8573-1
Oil content	3	acc. to ISO 8573-1



## 9 Optional trigger and query systems

### 9.1 End position feedback

The feedback device is located at the bracket SV04. By the installation of inductive proximity switches M12x1 and a switch cam, the position "OPEN" and/or "CLOSED" can be queried, respectively.



Figure 18: Butterfly valve type SV04 with pneumatic actuator and end position feedback

### 9.2 Control and feedback head TOP LED

The control and feedback head TOP LED is an extension module for the pneumatic actuator PAMS. The valve position detection is done by proximity switches. The integrated pilot valve controls two single-acting actuators. In case of double-acting actuators, two pilot valves control the actuator.

The design of control head and pneumatic actuator allows for an internal control air flow without external hoses. Apart from the electric position feedback, the device status is displayed optically at the control head itself by a mechanic position indicator.

The control and feedback head can be adapted to any M&S standard element. A splashwater-protected housing contains both the proximity switches for position query and the pilot valves required for triggering.





Figure 19: Butterfly valve type SV04 with pneumatic actuator and control head TOP LED

For further information please refer to the operating instructions "Control head TOP LED".

You can find this manual under the following link on the internet:

[Link to the operating instructions Control and feedback head TOP LED](#)



### 9.3 Control head AS-i

The control head AS-i is an extension module for the pneumatic actuator PAMS with an AS-Interface field bus interface. A contact-free analogue sensor element detects the valve position after detecting the valve end positions automatically by means of the teach function during commissioning and storing them. The integrated pilot valve controls single- or double-acting actuators.



Figure 20: Butterfly valve type SV04 with pneumatic actuator and control head AS-i

For further information please refer to the operating instructions "Control head Type 8691".

You can find this manual under the following link on the internet:

[Link to the operating instructions ASI control head Type 8691](#)





## 9.4 Electro-pneumatic position controller (EPPC)

With the electro-pneumatic position controller (EPPC) for the pneumatic actuator PAMS, the actuator position or the valve disc position is controlled according to the set position value. The set value specification is done by an external standard signal 4 to 20 mA or via AS interface.



Figure 21: Butterfly valve type SV04 with pneumatic actuator and electro-pneumatic position controller (EPPC)

For further information please refer to the operating instructions "Digital electro-pneumatic position controller type 8694".

You can find this manual under the following link on the internet:

[Link to the operating instructions electro-pneumatic position controller type 8694](#)



## 9.5 Electro-pneumatic process controller (EPPC/PR)

With an electro-pneumatic process controller (EPS/PR) for the pneumatic actuator PAMS, the actual value of the process factor is directly applied to the device as a 4-20 mA signal. The process controller calculates the set value for the position controller by a set/actual value comparison.



Figure 11: Butterfly valve type SV04 with pneumatic actuator and electro-pneumatic process controller (EPPC/PR)

For further information please refer to the operating instructions "Digital electro-pneumatic process controller Type 8693".

You can find this manual under the following link on the internet:

[Link to the operating instructions electro-pneumatic process controller type 8693](#)





# Armaturen GmbH

**Armaturen, Rohre, Sonderteile** aus Edelstahl  
fittings, pipes, special parts made of stainless steel

**Industriestraße 24-26 · 26446 Friedeburg · Germany**  
**fon +49(0)4465 807 0 · fax +49(0)4465 807 40**  
**[www.ms-armaturen.de](http://www.ms-armaturen.de)**